

Actual aspects of development of mechanization of trial works in plant growing

V. Adamchuk,

Academician of the National Academy of Sciences of Ukraine, Doctor of Technical Sciences
National Science Center "Institute of Mechanization and Electrification of Agriculture"

V. Bulgakov,

Academician of the National Academy of Sciences of Ukraine, Doctor of Technical Sciences
National University of Bioresources and Natural Resources of Ukraine

V. Gorobey,

Candidate of technical sciences Scientific and production association "Selta" of the National
Scientific Center "Institute of Mechanization and Electrification of Agriculture"

The purpose. To study state and development of technical maintenance of selection-and-seed-growing work with grain and leguminous cultures in Ukraine. **Methods.** Analytical, statistical, modelling and empirical research of working organs, units of machines and technological operations. **Results.** Overall performance of machines available in selection centers for mechanization of selection-and-seed-growing processes is determined at work with grain and leguminous cultures. The gained results of researches are directed on development and introduction in agrarian science of perspective machines for basic operation of selection — sowing. Basic directions of development of technical maintenance of selection and seed-growing of grain and leguminous cultures are brought. **Conclusions.** For mechanization of selection-and-seed-growing processes of grain and leguminous cultures there were developed more than 40 machines, process equipment and devices which were made by small parties or were recommended (>75%) to serial production. Production of selection machines should be supported by state.

Key words: *mechanization, selection machines, agrotechnological requirements, machines, type, devices, process equipment, design, production, modernization.*

FORMULATION OF THE PROBLEM

Measures to increase the production of grain will be more effective in well-organized seed production - providing production crops with high quality seeds of more productive varieties. Scale, pace and nomenclature of machine technology technologies are agreed, as is known, with the volumes and rates of increase in production volumes of the corresponding crop production.

The current situation regarding the development, production and improvement of domestic breeding equipment, with the stopping of the work of a specialized enterprise with unique bases of design developments and production facilities of the "Selta" NPO NSC "IMESG" (Simferopol) [1-3] and MNSPP Klen (Lugansk), which mastered the production of breeding seeders on a modern element base, does not satisfy breeding establishments and breeding and seeding centers and requires the adoption of appropriate sectoral and state decisions.

The introduction of advanced technologies for the cultivation of grain and leguminous crops on the basis of complex mechanization and automation of production also require the expansion of the use of new technologies, automatic control systems, new information and technical solutions and machines to accelerate the implementation of advanced varieties with consideration of time requirements, which will allow to increase quality indices for agrotechnological requirements in breeding and seeding processes and accelerated production of high quality seeds.

ANALYSIS OF LAST RESEARCHES AND PUBLICATIONS

Mechanization of works in breeding and other scientific researches allows not only to increase productivity, but also to reduce the terms of work execution, improve the quality of technological operations, the reliability and reproduction of results, their accuracy, increase the volume of research and improve working conditions, and this, in turn, reduces the length of the output of the variety, increases its quality [4-8].

One of the important conditions for seed production, both in primary and secondary seed, is hard agrostyle. Almost a month, on average, the breeding and seeding center, where the primary links occupy up to 30 hectares and the secondary 800-1000 hectares, it is necessary to harvest the crop, prepare it for sowing (up to 5 thousand tons of grain for 2 weeks) and sow more than 100 thousand ears

The volumes and number of varieties occupied in primary and secondary seed, the required amount of machinery is determined. This is usually not less than 2 cassette seeders, 2 servings, 4 ordinary type SZ-3.6 or "Maple", hamsters 5 spikes, 5 roundabouts, at least 3 seed clearing machines with productivity up to 150 kg, cleaning machines with a capacity of 1 ton and above - no less than 5. Work is often organized in this period in three changes. In addition, there must be no less than 2 breeding and 2 seed combines, for spicy and free-standing crops, due to the additional clogging of the Trier and the Norie harvesters.

For technological works in secondary seeding for the preparation of soil, usually 3, 5, case, cultivating and reversible plows are used, as well as other agricultural machinery of general production, fertilizing machines, cultivators, and easily cleaned seeders.

If technological operations on soil preparation and sowing in secondary seed are technically domestic producers can close, then the high-yielding purification technique for seed material is a matter, and harvesting is carried out exclusively by imported machinery, both in primary and secondary seed.

For the effective work of breeders-scientists on the removal of new promising varieties of agricultural crops, the introduction into production of new technologies, it is necessary to provide their jobs with special modern means of complex mechanization of technological processes.

Selection-research work imposes on the cars rigid specific requirements, the fulfillment of which is obligatory: exclusion of sorting, prevention of mechanical damage to the material, exclusion of losses, stability of the process, compliance with the parameters of the experimental field, maximum use of change time, maneuverability and ease of maintenance.

The world-wide production of breeding and seed technology is concentrated mainly in the firms of the industrialized countries: Wintersteiger (Austria), Sampo Rosenlew (Finland), Hege (Germany), Amako (USA), Westport (Denmark) . In Russia, breeding technology is used mainly by the production of the federal state budget scientific institution All-Russian Research Institute of Agricultural Mechanization and the federal state unitary enterprise Omsk experimental plant RASGN (FANO).

The main characteristics of the technology that they produce are high reliability, performance and functionality. High technical level due to the use of high-strength steels and wear-resistant working elements, economic profiles for frames, automatic devices for monitoring and providing the necessary qualitative indicators and load characteristics. Such a technique is created not only due to the competitive environment, but also the presence of specialized productions of the modern elemental base of machines.

In the practice of selection and seed processes for the mechanization of some operations and the reduction of the share of highly skilled manual labor, and to date, nodes and technical solutions from generic machines are used. When borrowing technical solutions from generic machines for the means of mechanization of research work - the disadvantages and simplifications are transferred to the breeding machines. Such a situation leads to the need to improve not only the working bodies and technological schemes of machines, but also on the basis of new knowledge to search for fundamentally new methods, devices and technical solutions that are specific to the research work [9, 10].

The systematization of requirements for machines, the unification of breeding works were determined by the practice of verifying rational schemes for the implementation of the technological process, the grouping of numerous nurseries at the conditional stages of selection in accordance with the number of seeds, the same type of operations, volume of work and rational use of the ground areas.

On the basis of research carried out with the involvement of domestic research institutes, inter-republican technical conditions (MRTUs) were developed, then converted into inter-industry standards (OST), according to which experimental areas are grouped according to purpose and method of performing the basic sowing operation. It is taken into account that the size of the sections, inter-sectional paths, turning strips determine the dimensions and design parameters of not only sowing machines, but also of the whole complex of aggregates for the care of crops and the collection of breeding material. Documents are regulating the beginning of the development of special machines, which is planned in accordance with the conditional stages of selection and research work [11].

To mechanize the technological operations of each of the four stages requires a set of machines that differ in design parameters, dimensions and performance.

The main problem is related to the production of breeding equipment in that the various standard sizes of machines require a lot, and the total number of each type, necessary for the full provision of the needs of them selection research institutions, is relatively small at a high cost of machines [3]. Therefore, when choosing the best options for the creation and introduction of new technology, the calculation of the economic effect, the assessment of the activities of enterprises and organizations, the estimated volume of production at small required quantities of products of new equipment (up to 100 pieces) was taken equal to the total need of the industry in products.

So, if in the production conditions the seeding is carried out by drills with different width of capture, and harvesting can be harvested combines of any other width, then in the breeding crops, the width of seizing of all successive machines for care and harvest should strictly correspond to the width of the seizing, and the motors and supporting wheels must pass along the inter-sectional paths, without passing or damaging the extreme plants of neighboring plots.

It is no accident that immediately after the approval of the methodological guidelines for determining the economic efficiency of agricultural crop varieties (1978), which states that part of the effect of the variety is the consequence of the use of new technology by the Ministry of Agriculture, work began with the participation of the Simferopol Branch of the Scientific and Production Association "Agropribor" on the establishment of common methodological principles for determining the economic efficiency of breeding and seed technology and laboratory equipment for villages farm economy.

The economic effect of new technology is the total savings of all productive resources (living labor, materials, capital investments), which is received by the national economy as a result of the production and use of new technology and control, ultimately reflected in increasing national income. The determination of the economic effect is based on a comparison of the reduced costs of basic and new technology. The costs presented are the total economic cost of new technology and directly proportional to the unit cost of production, capital investment in productive assets per unit of output and the normative coefficient of capital investments.

To calculate the share of the economic effect, which is the result of the use of new technology from the introduction of research (the withdrawal of a new variety, the justification of the new agro-acceptance), in which the new technique was used, the formula was proposed:

$$E_d = E_c m_n m_o ,$$

where E_c – the effect of the introduction of a new variety or agro receptacle; m_n – the coefficient taking into account the share of a research organization in the effect of the introduction of research work; m_o – the coefficient, taking into account the share of the effect of the operation (soil preparation, sowing, introduction of biologically active substances, harvesting, post-harvest cultivation), which is carried out using new technology.

In part, the effect of the research organization, which is determined expertly for grain crops with the construction of a structural scheme of economic efficiency. The block diagram should have a hierarchical structure. "Economic efficiency" is located at the highest zero level structure, and less complex indicators - at the first level. In turn, each of these indicators in the structure consists of a number of indicators of efficiency (or means of achieving), being at the second level, etc. When constructing a hierarchical structure, it is desirable to proceed to such a low P-level, which contains single or complex indicators, for which there are objective methods of evaluation.

The analysis of the negative tendencies in the field of breeding and seed production in Ukraine suggests that one of the reasons for the weak competitiveness of domestic varieties, hybrids and seed products is among other things the low level of technology and technical support [12].

The questions of the potential of national breeding science, discussed fifteen years ago at round tables at the state level, concerning the acute need to update and align with the time, the needs of the market economy of its material and technical base with the appropriate involvement of the capacities of the specialized enterprise "Selta" [13] have not been solved, but, on the contrary, have become more relevant, despite the fact that since the late 90's more than 75% of the basic breeding and seed technology "Selta" put into production. Moreover, the basic developments in the development and production of breeding and sowing machinery in Ukraine were mainly for technical crops (flax, hemp, tobacco), vegetable crops and fodder grasses - more than 120 technical means [1-3]. The task of ensuring the means of mechanization of breeding and seed production in cereal crop production was urgent. The overall design of the system of technical equipment was estimated at about 280 items and was periodically discussed at Coordination meetings with the participation of leading selecents in order to

introduce new ones for the production of machinery and withdrawal of non-prospective ones [14-17]. Due to the fact that in order to increase yields a significant role played by timely varieties and varieties renewal in the early 2000's was determined the list of the most needed types of cars necessary for the primary restoration of production of breeding and seed technology of 19 items.

The aim of the study. To investigate the state and development of technical support of breeding and seed work with grain and leguminous crops in Ukraine.

Research results. The survey of breeding centers and scientific organizations of NAAS (about 40) showed that the resource of most of the basic equipment used up to the present time has developed its depreciation terms or is approaching completion, the level of mechanization of selection processes, variety testing of cereals and leguminous crops often does not exceed 30% , others - 10%. As indicated by the generalization of orders, the total need for breeding and sowing machinery, as shown by the generalization of orders, is about 300 units, 60 names, including more than 50 units: soil tillage and sowing machinery, for threshing of plants, for purification of seed samples, special equipment.

Qualitative indicators of breeding equipment that were produced in the pre-perestroika period, according to machine-test stations, were not lower, and in some cars higher than in foreign analogues.

There is a lack of reliability indicators (due to existing restrictions in the use of high-quality materials, ready-made aggregates and nodes of other industries) and, of course, in aesthetic indicators.

To create economically expedient competitive machines for this direction at the stages of forming plans for research and development work (in the process of choosing a variant of the creation of new technology), when making decisions on the production of new technology - indicators of better designed or previously acquired selecents overseas technics, and at the stage of the introduction of new technology, including for advanced technologies - indicators of the technology being replaced. The structural scheme of the indicators up to $P = 5$ (the fifth level, taking into account the actual agrotechnological requirements) to determine the effectiveness of the means of mechanization of breeding and seed processes (Figure 1) leads to the search for new technical solutions of the working bodies and constructions.

During the years of independence in Ukraine, more than 80% of the basic machines for the mechanization of breeding, variety testing and primary seed production of grain and leguminous crops have been delivered, which have undergone departmental acceptance tests, implemented or prepared for production [15-17], using basic outputs by machines for additional soil preparation, plant care, type of seedlings for various stages of breeding work on traditional and energy-saving ground preparation technologies, threshing machines for individual grains and grain legumes, beans, shears; laboratory cleaning machines and seed production up to 500 kg / h, dryers for breeding and seed production.

Structurally improved on the remarks of the leading breeding centers of the car of the urgent need (new technical solutions (more than 30) protected by patents of Ukraine) were put into production:

- leveler-chopper soil VIP-2 (no analogues in the world);
- milling cutters in spring for continuous tillage of soil FNS-1,5; FNS-1,8 (no analogues in the world);
- cultivator milling KF-6 (in place of the rammer milling RF-4);
- seeder cassette selection SSC-6 (in exchange for SCS-6A);
- a seeder with a central distribution unit STS-10 (in return STS-10C-01);
- selective seeders with alternating SS-16; SNA-16A; SNS-16AP (in lieu of SN-16P);
- thorns of the colic MKS-1A and individual leguminous plants MBK-1 (in exchange for ISS-1; MZB-1);
- a threshing device for a spur gearbox МПС-60 (in lieu of МСР-50) and a thresher-torque a universal universal MPTU-500;
- Shustalka selection Sh-0,1 and breeding and seeding ShS-0,5 (in exchange for SHS-0,1 and SHS-0,5);
- Seed cleaning machines: LVA-1A; AK-1A, RASM-0,15 (in exchange for LVA-1; AK-1 and SM-0.15);
- Triier breeding and seeding continuous action;
- drying cabinets ССР-16x8 (in lieu of СР-16x8), solar drying mixes of various productivity (without the basic prototype);
- PS-3 seed dresser and transport chassis (without basic prototypes in breeding and seeding practice).

The above-mentioned machines are used to accelerate both breeding work at various stages of conducting researches with cereal crops, as well as in primary seed-growing units.

For the preparation of soil for primary seeding units, the leveler-chopper of soil VIP-2 is used; put on production of a mill for continuous tillage of soil FNS-1,8, having a reduced energy intensity of the technological process by 20% and increased operational reliability due to modernization of the cutter

structure FNS-1,5 [18]; For the processing of broad-row crops, a cultivator milling KF-6 was put into operation, which was developed on the basis of the cultivator RF-4.

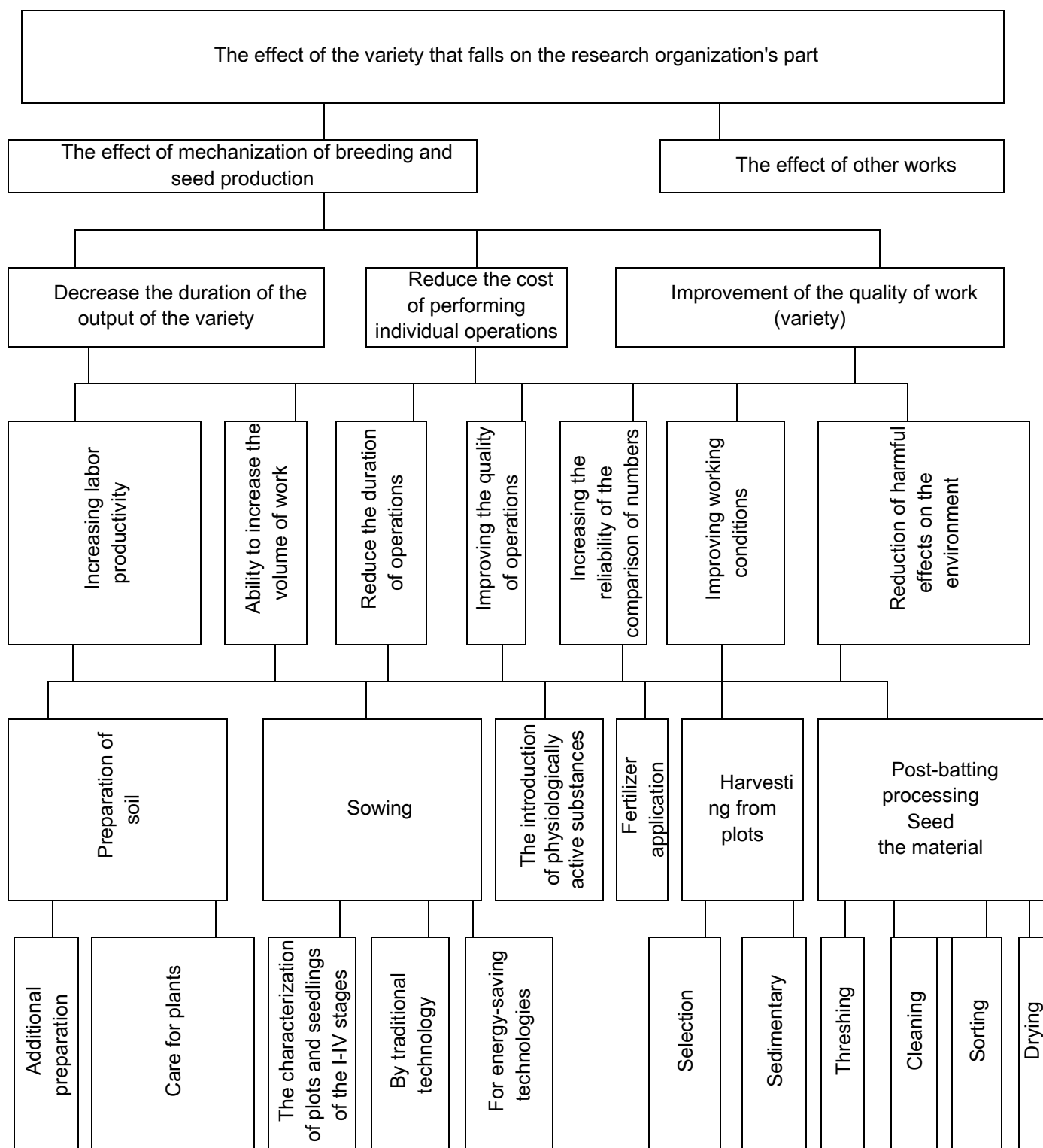

Fig. 1. Structure scheme of definition index of effect from the sort for definition effectiveness mechanization means of selection-seed-growing processes

In the technological scheme of obtaining higher plant productivity, the number being studied in the selection material, the basic technological operation is seeding. Available methods and technical means

for its implementation do not always correspond to agrotechnological requirements, which leads to losses and shortages of a large quantity of source material and delaying the terms of the output of the variety.

The seed drill SR-1MA is used for seeding in seedlings of 1 year progeny testing, in the seedlings of the testing of seedlings of 1 year, the "spike-row", the seed drill SSC-6 mounted on the chassis of the tractor T-16, an analogue of seeders SCS-6A (SCS- 10) production of MZOK VIM in Soviet times, which are used up to now in a number of breeding centers of Ukraine.

From foreign sowing machines of a central distribution and with machines of autonomous distribution of grain (cassette), cars, including self-propelled, are used by firms "Wintherstyager" [19].

Seeders SCS-6A (SCS-6-10) with seeding seeders are used for seeding seeds in seedlings of second-generation offspring testing (PB-2).

In addition, for sowing seeds in RV-2 on areas up to 0.5 hectares, seedlings with a seed sowing machine are traditionally used SCS-6-10; SCS-6A; CH-10L-0,1 and developed analogues, "Maple-1,5C", "Maple-1,5P" with electric drive of seeding machine and electronic control and control over the seeding process.

The seeding machine STS-10 for seeding on the third stage of breeding works with basic equipment of CH-10TS-0,1 with the electric drive of the seeding machine and the mechanical distribution of seeds on the coulters during sowing of the seed for a given length of the plot was developed and prepared for the production of seed. Seed according to rice. 2 a and b consists of a frame 5, coulters 1, a supporting wheel 2, a roller shovel 12, a gear box 6, a software box 13, a seeding machine, which consists of a dispenser 7, a seed distributor 8, seed lines 9, a cartridge conveyor 14, a cam shaft 16, shaft intermediate 15, mechanism of loading the dispenser seeds 17 and electrical equipment. The sowing frame has an autocamper lock 3, a platform for the operator 11 and a container for the cassettes with seed 10. The supporting wheels of the drill are fixed on a transverse beam of the frame with the ability to adjust the width of the track (the distance between the wheels), moving them along the beam. From the left wheel, all the mechanisms of the seeder through the chain transmissions are actuated.

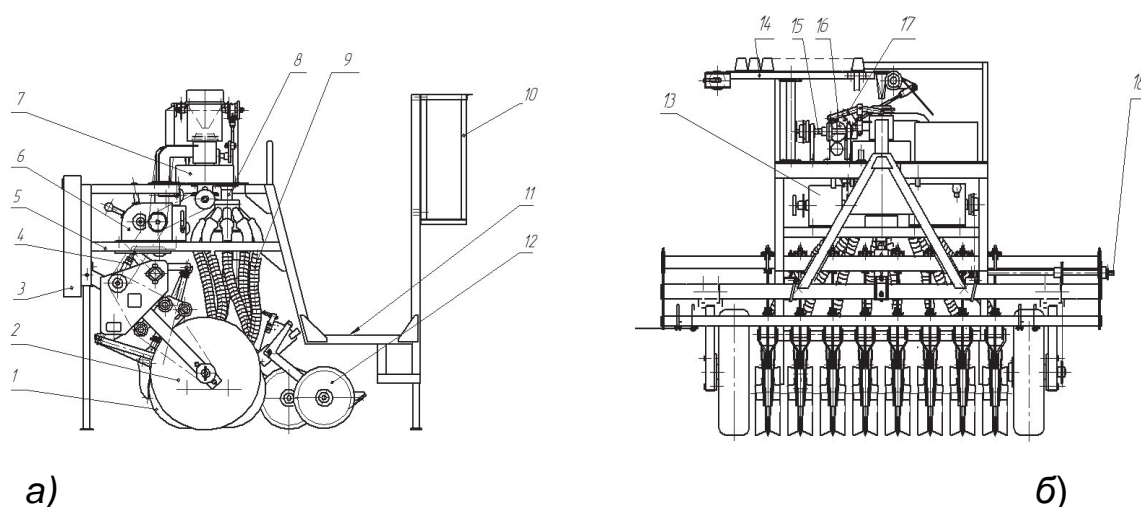

1-coat; 2-axle wheels; 3-lock car coupler; 4-screw mechanism of coulters deepening; 5-frame; 6-speed gearbox; 7-dispenser; 8-seed distributor; 9 seed lines; 10-container for seed cassettes; 11-site for the operator; 12-ringing rollers; 13 program boxes; 14 conveyor cassettes; 15-shaft intermediate; 16-shaft cam; 17-mechanism of loading the dispenser with seeds; 18-drive shaft.

Fig. 2. Scheme of the seeder CLH-10, look from one side (a) and look in front (b) for III stage

The coulters are fixed on the coil bar frame and have the ability to adjust the height relative to the frame using the screw mechanism 4. The distance between the adjacent coulters can also be controlled by moving them along the coulters beam. In the design of the drill, combined two-disk anchor coils are installed. The coulters consist of a body in which the two axles are mounted on the axles with the possibility of rotation of the forward angle in the course of the coulters movement. Between the disks with the case is a two-cheek holder. In the cavity formed by cheeks, a ball-shaped part with a bell and nasal and inserted into the case with a spring is inserted into the cavity, and to the cheeks of the holder with a

hinged suspension, which is arranged relative to the path of the coulter to the rear of the globular part. When using combined coulters, roller coasters are used. They are hinged to the shells of the coulter and have the ability to adjust the height relative to the coulter.

It is also possible to use two-disc, anchor or roller coulter. In case of the use of helical or anchor coulters, instead of rolling mills, the chain loops that are added to the seeder are used.

The gearbox is intended for setting the length of the seed, which is carried out by changing the adhesion of the tribal wheels of the box, which transmit the rotation from the support wheel to the dispenser. The gearbox has two levels of regulation.

The software box is intended for the formation of a cross-cutting track. The setting of the width of the inter-circular track is carried out by changing the adhesion of the tribal wheels, which transmit the rotation from the gearbox to the camshaft.

Field research of a seed drill with combined two-disk anchor coulters [20, 21] was carried out in the conditions of nurseries NSC NS SGA for sowing in areas of grain and leguminous plants on an area of – 30 hectares. Sivalkka attached to the tractor T-25A with a width of 2,0 m, with installed combined bushes with intermediate rows of 0,15 m, width of capture 1,5 m sown areas of 2 to 20 m in length of spring barley, winter barley and winter wheat, the norm of sowing 3,5; 4,0; 4,5; 5,0 million pcs / ha, wrapping depth 40; 60; 80 mm The length between the tiered track is from 0,35 to 0,65 m. Uneven seeding along the line 4%, uneven seeding between the coulters - 3%, shredding seeds to 1%. The capacity of the cassette, cm³ - 250, the number of cassettes in a sliced – block without stopping - 10. The drill ensures an even increase in the depth of seed placement by preventing the lifting of the lower part of the nursery to a height that does not exceed the size of the agrotechnical tolerance Δ_{agr} . With an average yield of seed grain 4.5 t / ha, an increase in yield of 5-7% when used for planting combined combines due to an increase in similarity compared to sowing with standard two-disc coulters, which in monetary terms makes 650-900 UAH / ha (as per 2015).

The frame of the design of this drill can be used to equip a seeding machine of an autonomous type that would satisfy the seeding conditions in the second stage of breeding operations - in each coulter to sow your seed number. Basic seeders of a number of SCS have a design of the drive, which is carried out only from the synchronous shaft of power take-off self-propelled chassis T-16, on which the drive star is installed. From the drive sprocket, turns are transmitted to a counter-propeller, whose shaft has a coupling, which activates the drive when the coulter is lowered into the ground and disconnects it when the coulter is raised. From the shaft of the counter-drive, turns are transmitted to the drive star of the gearbox, and from it to the drive sowing devices and a box with a software device. Other disadvantages include constructive decisions of all nodes of the drill, which, with the exception of the coil group and the thruster, are mounted on a frame of the T-16M chassis. In previous times, T-16M, as a rule, was deduced from commercial exploitation in the seed farming industry when installing such a drill on it, since its installation and adjustment were labor-intensive and required special conditions. According to agrarian breeders used a seeder, which is installed on the chassis for 14-28 days a year. Thus, the T-16M chassis was put out of operation in the farms from six months to a year. In addition, the factory-manufacturer took it out of production. The well-known hinged seeding seeder "Klen", which hangs on a tractor behind for sowing on multi-row sections of the third stage, where all seed lines of the same variety are sown with a portion type seed - a portion of seed is sown on a section of a given length [22] and, similarly, as SKS-10 can not be used for sowing grain, leguminous and cereal crops with observance of agrotechnical requirements for the second stage of breeding and seed production.

Therefore, the task of developing a design of a universal mounted seeder with seeding machines of autonomous distribution (for the second stage) and seeding of different seeds numbers and put on production is relevant.

The task is solved by the fact that the seed hanger selection cassette (CHCK-6) contains a frame, a support wheel, a support wheel, seed lines, seeding machines with cones, rolling rolls, a gearbox, a software box according to the invention, a cassette table with cassettes is installed on the frame , which contain separate cells connected to the seed coulters through seeding machines through seeding machines for seeding various numbers, and the cones of seed machines are installed inside their shells and are connected by means of cone gear with a shaft of the seeding apparatus s connected to the gearbox and transmission program for controlling rotations of cones, with cassette desk placed along the axis of motion drills with access to it and to the tapes on both sides.

The kinematic scheme of the proposed selection of grain seeders is presented in the drawings of rice. 3. The drill works as follows. When moving in the field support and drive wheel of the drill leads to the rotation of the shaft and dispensers of all seeding machines. Seeds from the axis of cassettes on seed lines enter the dispensers, which evenly distribute them to the length of sowing. From the dispensers of seeds through the seed pipelines enters the coulter and sown in the grooves. When rolling rolls, which are fixed to the coulter, close the grooves.

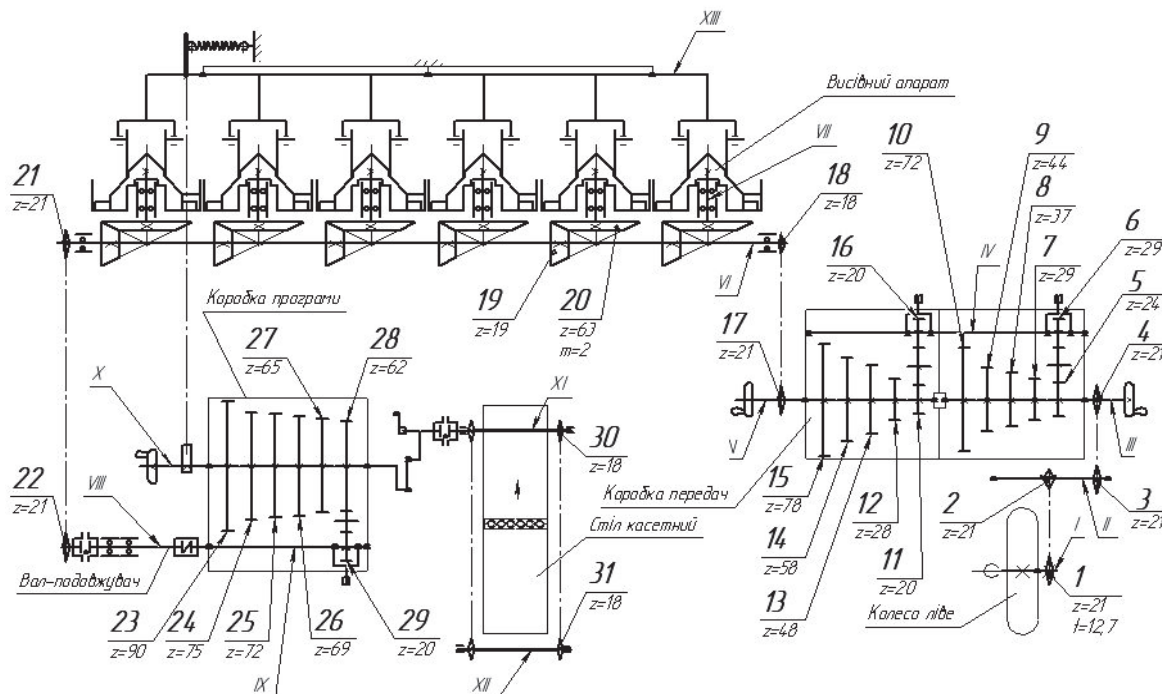

Fig. 3. Scheme cinematic of the hang selective cassette seeder CHCK-6 for II stage

The work of the drill is carried out when adjusting for the automatic loading of seeds into the seeding machine and the automatic formation of inter-chain tracks. During the working movement of the unit of rotation from the drive wheel of the drill, in accordance with Fig. 3 is transmitted to the gearbox, the tribal wheels of which are included in the given seeding length. From the transmission through the chain gear $Z_{17} - Z_{18}$, the chain gear $Z_{21} - Z_{22}$ and the gear transmission $Z_{28} - Z_{29}$ rotation is transmitted to the shaft of the program box, which contains the cam and crank crank mechanism of the cassette table.

Before the start of the worker movement of the unit, the shaft of the cassette table manually for the handles set to the beginning of the seeding. Then, the conveyor of the cassette table is manually scrolled so that the seed from the first cassette is poured into the cylinder. After this, the working movement of the unit begins, with the cam release the lever, which under the action of the spring will raise the cylinder and the seeds from it on the cone hanging in the dispenser. During the passage of the set length of seeding the dispenser will make one full turn and evenly transfer all the seeds to the coulter. During this time, the conveyor cassette moves one step and from the next cassette the seed hovers in the cylinder. With further movement of the unit, the seed is not sown because it is not in the dispenser. In this way, an interlayer path is formed. During the passage of the unit by a distance equal to the installation of the corresponding tribal wheels of the program box, the width of the inter-circular track, the cam shaft will complete the first full turn from the beginning of the worker movement and pour into the dispenser the next dose of seed, and at the same moment it will start hanging. The process is repeated until the seed is sown from all cassettes.

For seeding at the fourth stage of breeding and seed production, the seeder CH-16, which is completed, was traditionally used for seeding in the State Register of Varieties of Ukraine (for further works on primary seed) at intermediate stages between breeding and seed production, preliminary, competitive, state variety testing of varieties for inclusion in the State Register of Varieties of Ukraine a seed drill of a reel type for sowing small, medium or large seeds, 16-threaded or 13 double-disc coulters, a width of capture of 1.8 m, harvesting after sowing by a com Bye "Sampo-500" with a reaper, width of capture 2.2 m.

disc 1 of the combustion unit, set at an angle of 4-6 degrees to the direction of motion and is connected to the mechanism of self-oscillation 14

The seed drill includes an electronic seed management system powered by a tractor's electrical mains with a microprocessor control unit (MBU) 19 and a gear motor 20, a shaft with reel sowing machines 21, a probe track 22, a chain drive 23 for the speed of the support wheel 24, wheel 25, hopper 26, funnel 27, seed line 28, frame 29, automatic coupling 30 and universal bushings located in two rows: front 31 and rear 32.

The use of a successively located gear knife that cuts ground 16 and a toothed disk, 1 socket unit, set at an angle of 4-6 degrees, plate-spring suspensions 17 for cutting knives, an 8/9, 10/11 lever-spring mechanism for coil units and the spring mechanism of self-oscillations 14 allows, at the expense of the vibration effect, to reduce the energy intensity of the seed drill when sowing for energy-saving technologies. The depth of the comb is controlled by the mechanism of adjusting the position of the rolling roller 5 along the grooves of the vertical planks mounted on the bracket on the rear end of the body 4 of the combustion unit.

Thus, an increased degree of unification of seedlings of hinged breeding and seeding, which provides the possibility of additional use of them as direct sowing machines in the implementation of technologies of minimal and zero cultivation of soil without a fundamental change in the basic design of the drill..

The design of the SS-16 seeder seeder with a re-actuated sowing machine of a reel type from a mechanical to an electric drive was introduced at the NSC "Institute of Agriculture" of the National Academy of Sciences of Ukraine.

Confirmation of performance, observance of agrotechnical requirements, determination of traction resistance and influence of vibration effect on it, applied on researches of the proposed technical solutions, was carried out on experimental samples of coiled units with toothed disc cutters on specially prepared equipment under laboratory conditions of the ground channel of PF NUBiP "KATU" (Agrarny village, Simferopol city) and field trials in the economic conditions of LLC "Fertilizer" in the village. Pyatykhatki Krasnogvardeysky district of the Autonomous Republic of Crimea.

The tufted knot with a toothed cutting disk and anchor began to work on treated and untreated fields containing plant residues in the surface layer up to 480 g / m². Plant residues at the bottom of the grooves that were created were absent. The width of the strip of deformed soil did not exceed 0.025 m.

The soil hardness was determined with the help of a hard-rocker Yu.Yu. Reviakina in field conditions. During the work of the device on the treated soil, a plunger with a diameter of 0.02 m was installed on the unprocessed - 0.016 m in diameter. The stock of the stock was exposed only to the upper horizon in the range of 0.08 m, which was determined by the depth of seeding. The repetition of measurements occurred on the background - 3. Soil humidity was calculated according to the standard method and did not exceed 7-8% in the first case, and in the other 10-15%. The diagrams obtained in determining the hardness of the soil, confirm the previously made assumption of a practically linear nature of the increase in voltage as the stroke is pushed. The obtained values of hardness for surface treatment - 0,85 MPa, according to the stubble - 1,7 MPa. The hinged mounting of the frame of the support-pinion device of the coil unit reduces the load on the details of the lift mechanism, reduces the overall dimensions of the coil unit. The use of a sequentially spaced cut-off knife and a coil unit with a toothed disk, anchor or articulated coil, as well as plate-spring suspensions for knives, a spring-pressing mechanism for coil units and a spring mechanism of self-oscillations allow, by means of a vibrational effect, to reduce the energy intensity of a seed drill in a seed for energy-saving technologies. The indicated technical solutions can be used in seedlings in hinged breeding and seeding for sowing in untreated and minimally cultivated soil (mini-till, no-till and strip-till). Technical solutions determine the compatibility of the fitting with the toothed cutters that cut the soil, on the additionally mounted hollow square beams, the frame of the drill and the combustion units with toothed discs, coulters and rollers, which are rolled up with the basic, partially reinforced, frame of the drill without changing its basic design.

For the threshing of grain in the primary units of seed production put the main machines: threshing wheels of individual ears, bands and shears MKS-1, MZB-1 (MBK-1); MCYU-500 (MPC-60); MTPU-50 (MSST-0,5). Need a mobile table throat koloskovaya.

Modernized machines, both elemental and constructively, according to the breeders' comments: for purification and sorting of samples of the zostule seed, selective SHS-0,1 and seeding ШС-0,5 (productivity up to 120 and 500 kg / h, respectively); trier continuous operation with productivity up to 160 kg / h; cleaning machines with different productivity from 3 to 500 kg / h. (LVA-1A, RASM-0.15, AK-1M).

Necessary for primary seeding pneumatic sorting table and air conditioner (capacity up to 200 and 1000 kg / h, respectively).

From the dryers for breeding and seed production, a drying box dryer XY-16h8 was put into operation, intended for drying seeds of various crops in bags or mashings. To dry the seeds use an air-warmed air from 7 to 21 ° C in the electric heater. The bulk can be dried simultaneously to 16 samples, the weight of each sample up to 8 kg. First of all, the necessary development for working with grain in Ukraine is a tray dryer, an analog SL 0,3x2, which provides drying seeds of different varieties of two lots of 300 kg or four for 150 kg.

Under the prevailing conditions, the limited possibilities for creating breeding and seed combines are extremely necessary for harvesting from research sites. As the "Classic", "Quantum", "Delta", "Split" combines of the Wintersteiger company are virtually unavailable even for leading breeding centers, the most desirable is the Terrion-Sampo breeding harvester SR 2010 (reapers, m: 1,5; 2,0; 2,3) of the company (Sampo Rosenlew). Own experience of setting up the production of combines for the calculation of green mass KZM-14, combine selection for highly stemmed crops CSR-12 and the development of breeding grain harvesting KS-1,2 and breeding and seeding KSS-1,8 (GKSB for grain harvesting machines and self-propelled chassis) [25] with the unification of working bodies and units with machines for agricultural production - potential objective components of the successful solution of an important national economic task.

Private seed farms use the combines Slavutich, Don and others, which, as a rule, due to the difficulties of cleaning, are not widely used in seed centers, which carry out work in breeding nurseries of 1 and 2 years, and cook superlit and elite.

Combine harvesters of the "Hege" and "Sampo" series, which have already been removed from production, still work in domestic breeding centers. To solve the urgent problems arising from their exploitation, the experimental production of the NSC "IMESG" was developed and manufactured by the Sampo-500 combine harvester (intended for harvesting from the sites of the previous and competitive variety testing and is one of the most widespread in this class in Ukraine) to the harvesters of the combine harvester "Sampo-500" which saves almost

300-600 UAH / ha for sunflower harvesting; Closed-type drum that reduces injury and grinding of grain and a sieve with a separating surface of a combined type, which, when used with a closed drum for harvesting cereals and legumes, reduces the time of unloading the combine harvester from 45-60 minutes. up to 5-10 minutes, which provides savings of reduced costs 750-1200 UAH / t. In addition, the NSC "IMESG" supplied the main spare parts for this combine.

Conclusions

According to the project "Systems of Mechanization and Automation of Selection and Seed Processes in Plant Production", which includes more than 280 names for the mechanization of breeding and seed processes of cereals and legumes, more than 40 types of machines, process equipment and devices that are manufactured in small batches or recommended (> 75%) to serial production, including: machines for additional soil preparation - 4, seeders - 4, adaptations for combine - 3, hamsters - 5, plant care - 1, for purification Tanks of seed material - 6, sorting - 2, drying - 3, seed drill - 1, devices - 5, transport devices - 1. The main selection equipment in research institutions is already used for several normative terms of service, outdated. The production of breeding equipment should reach the desired level with state financial support, which requires the creation and development of new research and production in return for the lost specialized enterprise "Selta". For the transfer of breeding equipment to the modern technical level it is necessary to implement economically feasible successful technical and technological solutions in machinery, technical means and equipment for sowing, cleaning and sorting seeds. For the creation at the present stage of high-efficiency grain-harvesting and harvesting machines, the prospect of cooperation with the known European developers and manufacturers of this technique remains the most urgent because of economic expediency. Updating and matching with time, the needs of the market economy of the material and technical base of breeding science is the most effective, cheapest and most accessible means for increasing the production of agricultural products.

Bibliography

1. Catalog for ordering machines, instruments, laboratory equipment for the mechanization of works in breeding, variety testing and primary seed production / Under the general. Ed. Yu.A. Semenov - Simferopol: the Crimean region. polygraphizdat. 1983. - 75 p.
2. Catalog for ordering machines, instruments, laboratory and technical equipment for mechanization of works in breeding, variety testing and primary seed farming of crops / Under the general. Ed. Yu.A. Semenova, Yu.F. Nekipelova - Moscow: AgronitEIITO, 1988. - 149 p.
3. Machines and laboratory equipment for breeding in crop production: Ref. allowance / Under total. Ed. V.M. Drinky - Voronezh: NGO "MODEC", 2010. - 432 p.
4. Mechanization of experimental work in plant growing / Overview information. D.B. Dunaevsky, E.N. Konyushkov, N.I. Filenkov, V.P. Drunk / M.: VNIITEI selhoz, 1971. - 126 p.
5. Type of technical means for mechanization of field works in selection and primary seed-growing of grain crops // Development of mechanization of plant growing and animal husbandry: Sat. scientific works; Ed. V.G. Egorova / M., 2000. - P. 15-20.
6. Peday N.P. On the creation and demand for promising breeding equipment // Machine technology and technology for the production of cereals, oilseeds and leguminous crops: Sat. sci. doc. Intern. scientific-practical. Conf. "Agricultural mechanics in plant growing" (December 18-19, 2001), T. 3, part 2. - M., 2001. - P. 183-194.
7. Aniskin V.I. State and prospects of development and production of selection equipment for cereals and leguminous crops // Engineering in agriculture. - 2003, No. 5. - P. 3-7.
8. Aniskin V.I. Mechanization of Experimental Works in Selection, Variety Testing and Primary Seed Production of Grain and Leguminous Crops. Aniskin, Yu.F. Nekipelov. - Moscow: VIM, 2004. - 200 p.
9. Wiseman B.R. A sorghum planter for small experimental plots / B.R. Wiseman., R.I. Johnson., N.W. Widstrom, W.W. McMillian "Argon. J.", 1972, 64. - P. 557-558.
10. Steven By., E. John. One drill for all establishment systems – is it possible / By Stevens E. John, K. Paul Jarman, Peter Clarke, John G. Hampton Proceeding of the 12 International Conference and Exhibition on Mechanization of Field Experiments // 5-9 July 2004, Saint-Peterburg, Pushkin, Russia 2004. - P. 94-102.
11. Unified methods of primary and elite seed production of cereals, legumes and groats / Methodological guidelines / Ans. For the issue of V.G. Wolf. Kharkiv. Ukrainian Order of Lenin Research Institute of Plant Genetics, Selection and Genetics them. V.Ya. St. George's. - 1975. - 44 p.
12. Makrushin M.M. Seed production (methodology, theory, practice): textbook / M.M. Makrushin, Ye.M. Macrocushin - Simferopol: VD "ARIAL", 2012. - 536 pp.
13. Zhurakivska Z. Selection: investing a thousand, reaping - million / Uriadovy Courier, 2001. - No. 132 (2059).
14. Loss of cleanliness of the selection material when performing mechanized field works at breeding sites / Methodological guidelines. O.S. Kharikov, E.V. Zozulya, L.N. Kazantseva, A.V. Peshkov / M.: VNIIZH them. A.I. Baraeva, 1988. - 16 sec.
15. Goroby V.P. Creation of a domestic system of machines for breeding and seed production in Ukraine / VP Gorobey // Scientific works of the PF of NUBiP "KATU". - (Sir "Technical Sciences"). - Simferopol, 2010. - No. 131. - P. 119-123.
16. Gorobey V.P. The development and study of technology for agrarian science in plant growing in Ukraine // V.P. Gorobey, A.L. Krasnichenko Materials of the International Conference of the Nordic countries // From the Field experiment to the creation of sustainable agroecosystems in a changing world: methodology, tools, implementation. - Part 1. St. Petersburg, 2010. - P.44-46.
17. Gorobey V.P. Breeding equipment for grain and legumes / VP Goroby // Bulletin of Agrarian Science. - Kiev "Bulletin of Agrarian Science". - 2012.-11. - P. 49-53
18. Goroby V.P. Substantiation of combined working bodies of cutters for continuous tillage of soil FNS-1,5 / VP Gorobey, V.A. Luzin // Bulletin of the Engineering Academy of Ukraine. - 2012, No. 3-4. - P. 69-71.
19. <http://www.wintersteiger.com.ua>.
20. Bulgakov V.M. Improvement of the design of a combined double-disk anchor coil / Bulletin of Agrarian Science / V.M. Bulgakov, VP Gorobey // Kiev: "The Bulletin of Agrarian Science". - 2016, No. 4. - P. 53-57.

21. Gorobey V.P. Investigation of the experimental selection seeder STS-10 in field conditions // VP Gorobey, MA Litvinenko // Sb. sciences works of Kirovograd national tech un-th - Kirovograd, 2013. - Part 2. - Whip 43. - P. 73-78.
22. [http:// www.klen.lg.ua](http://www.klen.lg.ua)
23. Adamchuk V.V. Justification of the parameters of the machine's coulter for growing crops of winter crops / VV Adamchuk, V.B. Onishchenko, VV Town Hall // Mechanization and electrification of agriculture: intersection. thematic sciences save - K., 1991, Vip. 73. - P. 29-31.
24. Adamchuk V.V. Theoretical prerequisites for determining the energy characteristics of a coil with a toothed disk on a vibration damper / VV Adamchuk, VM Bulgakov, VP Gorobey // Kiev. "Bulletin of Agrarian Science". - 2015, # 2. - P. 45-49.
25. Alekhin N.I. Selection and selection-seed-harvesting combines / N.I. Alekhine, A.D. Alekhine, A.M. Chaly // Selection and seed-growing. - M., №3. - 1986. - P. 53.
26. Bulgakov V., Adamchuk V., Gorobey V., Olt J. Theory of the oscillations of a toothed disc opener during its movement across irregularities of the soil surface. – Agronomy Research. 2016. Volume 14. No 3. – PP. 711-724.